



Forward Planning & Design

www.dispensary-equipment.co.uk
www.pharmacy-fridge.co.uk
www.chemist-equipment.co.uk
www.display-fittings.co.uk
www.healthcare-furniture.co.uk

Dispensary

Furniture & Fittings
Healthcare Workspace Specialists



2007



**Dispensary, Surgery, Hospital & Healthcare
Furniture, Refrigeration & Storage Solutions**

- Bench and Worktop Units
- Full Height Units
- Desks and Workspace Units
- Drawer Units
- Controlled Drug Cabinets
- Accessories
- Retail and Waiting Area Fittings
- Consultancy rooms
- Showcases
- Medical Refrigeration



Concept to delivery

1 Estimates and Design

Need a price?

When the clock is ticking and you need a quick response, call our mobile sales hotline 07921 863736 should this number be busy please leave a detailed message repeating your telephone number and we promise a callback.

Out of hours...

Alternatively visit our website www.dispensary-equipment.co.uk here you will find 1000's of products used by pharmacy dispensaries and chemist retailers. New products are being added weekly, look out for special offers.

Looking for a design?

Ask for our Planning & Design service—costs start from £350.00+ based on clients supplying a floor plan with dimensions. Detailed site surveys cost from £400.00 per day. Clients receive A3 colour paper versions plus emailed or CD Adobe PDF file formats.

*Please note

Our estimating department charges for the preparation of detailed written quotations for bespoke items not listed.

Full procurement and quotation services are available please ask for more details.



Manufacture and Procurement

Production

Forward Planning & Design produces an array of fixtures and components specifically for pharmacies in retail, surgery and hospital environments. If an item is not in this catalogue or displayed on our website it can usually be manufactured or sourced.

Materials

Our skilled workers and machinery can turn your ideas into reality:

- Plastics
- Timbers
- Metals

Procurement

Allow us to search for products on your behalf to negotiate bulk purchases. Forward Planning & Design advisory team has in-house software to prepare tenders on your behalf, due to the complex nature of this service prices are negotiated per job requested. We create a specification report and if necessary prepare working drawings if a standard component is not readily available at a competitive price. Costs start at £500.00

2



3 Delivery and Installation

Delivery

Q. How much time should you allow for delivery?

A. *If the item is bespoke allow at least 4 weeks from time of order. Standard products normally take between 7-14 days.*

Q. Can I see samples of materials?

A. *Yes, we can send samples, there is a charge for all items requested, a credit is refunded with your order, or send them back in good condition and you will be entitled to a full refund less carriage costs.*

Installation

Q. Can you install?

A. *Yes, these can only be quoted based on the following information being available:-*

1. Location
2. Day, Evening or Weekend installation
3. Parking
4. Accessibility

"Our company policy is to deliver quality products not false promises"



To Order Call: 0113 350 8696

Typical Layouts showing:

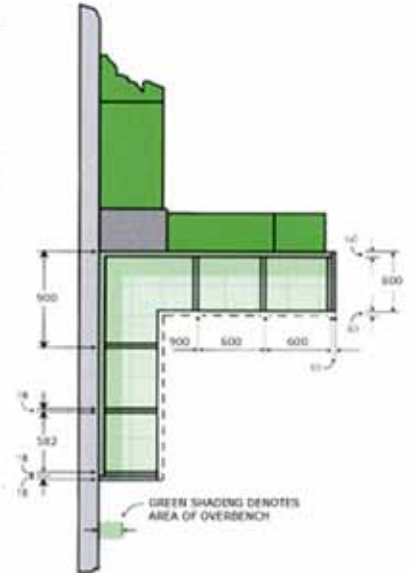
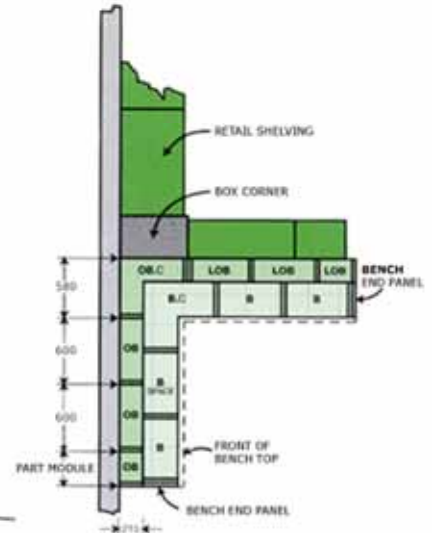
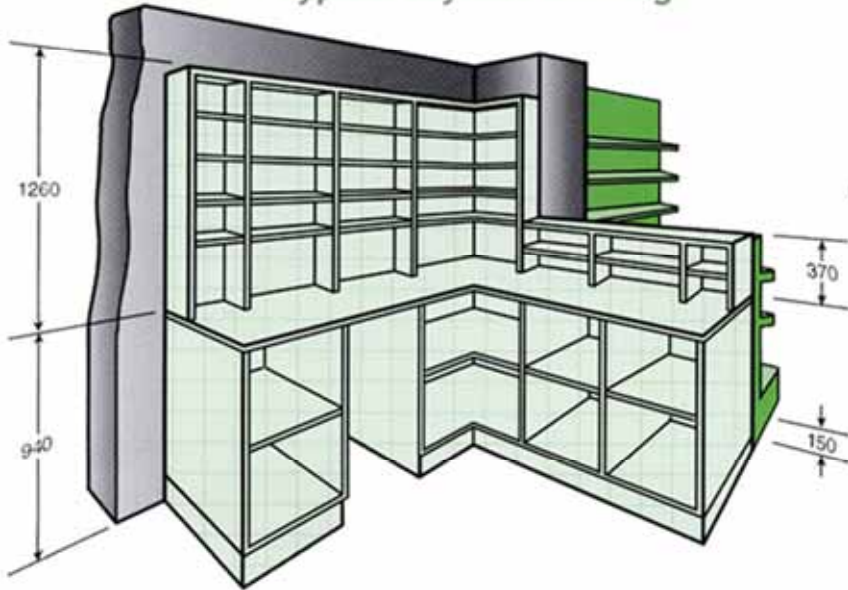

Full Height Units

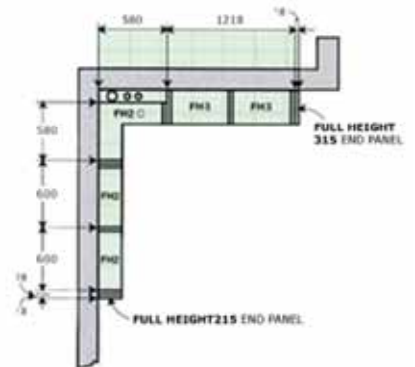
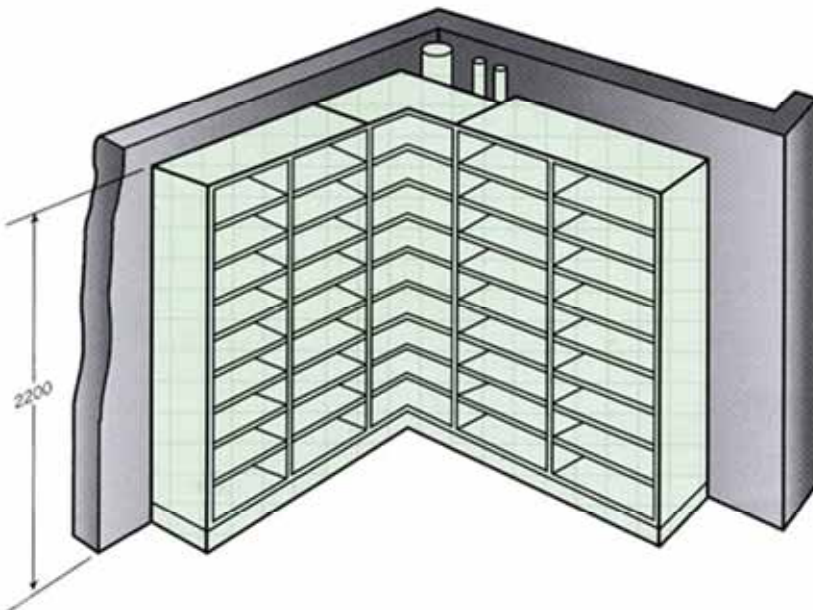

Overbench and Low Overbench

No need to compromise, maximize storage without losing valuable natural daylight from existing window openings.



Pharmacy Retail and Dispensary Storage

Retail environments design service. Custom counters, fascias, plinths and consultancy room areas.



Slat Wall Panels

Decorative and functional wall panels grooved horizontally to accept leaflet holders, hooks, shelves and signs.



Cupboard Doors, Waste Bin Unit, Bottle Rack

Bench Units optional extras and standard casework. Flexible shelving depths to accommodate all types of products.



Laboratory Standard Sinks

Choose from a basic style range or request high grade laboratory stainless steel, option to suit your budget and requirements.



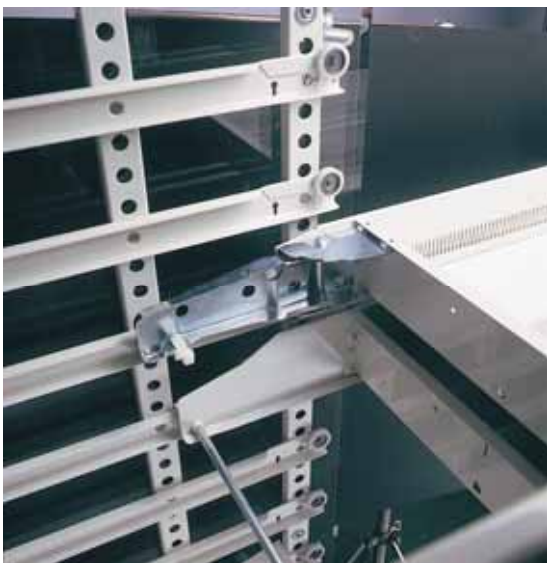

Willach Fama Drawer System

Highest quality continental drawer system, a proven product designed specifically for pharmacists. Available in a variety of depths and widths.

To Order Call: 0113 350 8696



Clip-on Dividers

A front and rear magnetic strip attaches to shelves. Dividers can be moved to suit product packaging sizes.



Configurations

Width Options:

- 450mm-Special Order
- 650mm
- 1000mm
- 1200mm-Special Order

Height Options:

- 1200mm
- 1360mm
- 1560mm
- 1800mm
- 2000mm
- 2240mm
- 2440mm



Configurations

Shelf Depth Options:

- 200mm
- 300mm
- 400mm
- 500mm

Shelf Strips:

- Ivory—Standard
- Red—Special Order
- Green—Special Order
- Blue—Special Order

Modular Pharmacy Metalwork

For buyers requiring a flexible system that can be moved to new locations without expertise or specialist tools. With such a multitude of accessories our design team is able to supply your department with both a storage and work bench solution. Lockable cabinets can be added for upper, mid and lower areas.

Central Units

Freestanding units for central room areas can be constructed to offer shelving both sides and end units.

Bespoke Timber Panels and Worktops

Almost any shape and colour can be manufactured to suit your space.

Call our sales department to ask about End of run clad panels and work surfacing.zf

Huge range of laminate and melamine material finishes to choose from.



To Order Call: 0113 350 8696





Peninsular Over Table Top

Custom Over Table top accessory, Single tier or multi level, available in a variety of sizes and finishes

Overbench and custom worktop cut-outs

Example shows low desk table shelf and Overbench shelves made to suit A4 files boxes. Radius corners for aesthetic appearance and comfort for movement.



Cable Access holes

Cable tidy holes positioned to suit. Avoid unsightly plug points and wires.

Reception Desk and Overbench units

Provide space for computer CPU under desk level. Adjustable shelves relocate easily every 32mm. Shelves have an option to include ticket edging—insert labeling signs for EPOS (electronic point of signage, bar-coding).

**Custom Work Surfaces**

High quality laminated work surfaces with 2-3mm durable PVC edging in timber and colour finishes.



To Order Call: 0113 350 8696

Full Height Shelving Units

Any length or height with a combination of shelves to suit your requirements. Depth dimension made to fit the space and products stored.

** Base cupboard options available for bulk storage with or without doors.



Switch plates

Existing light units can be accommodated or moved by your electrical contractors prior to installation.

To Order Call: 0113 350 8696

Adjustable Shelving

Quickly adjust your shelves without the need for tools, slide out and refit shelf plugs into new holes.

Please note:

- All narrow depth shelves are Anti-tilt.
- Option to angle shelf downwards.
- Option for extra shelf EPOS, Barcode ticket edging.



Wall Mounted Electrical and Communication points

Overbench Shelving Units designed with cable tidy holes.

- Units available in widths to suit all printer top devices.
- Standard unit wall heights approx 2200mm and custom fit.



Fax: Please call first

Briefly describe your desired feedback.

Dispensary

- Bench and Worktop Units
- Over Bench Units
- Full Height Wall Units

Reception & Sales Area

- Counters
- Reception Desks
- Signs and Window Display

Comments:

Storage

- Wall Racking and Shelving
- Central Racking
- Mobile Units

Security

- Controlled Drugs Cabinets
- Weights and Measures
- Medical Refrigeration

Company Name & Contact

Address

Phone



ATJ Hopkins

Group of Companies

Forward Planning & Design
www.dispensary-equipment.co.uk
www.pharmacy-fridge.co.uk
www.chemist-equipment.co.uk
www.display-fittings.co.uk
www.healthcare-furniture.co.uk

12 Haven Gardens
Cookridge Towers
Leeds, West Yorkshire, England
LS16 6SN

Phone: 0113 350 8696
Fax: 0870 478 2794
E-mail: sales@display-fittings.co.uk